

KEYWAY W=4.75, D=2.4
AT 45° CLW

UPPER PUNCH

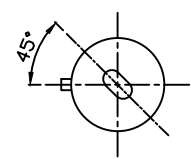

LOWER PUNCH

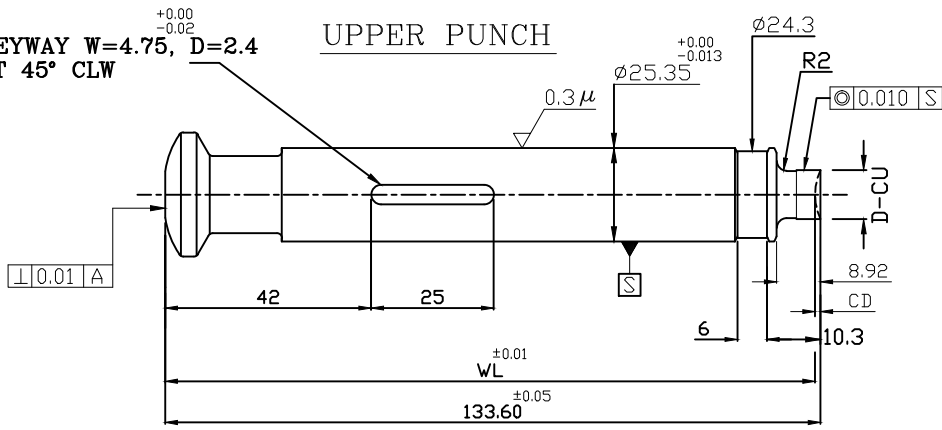
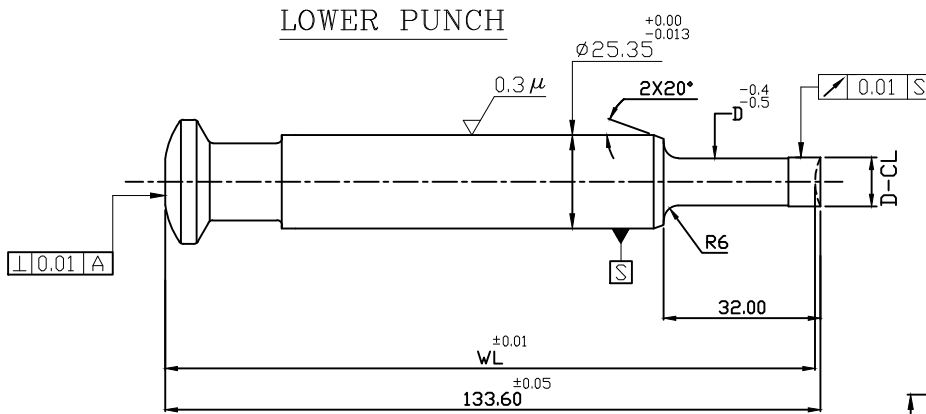

HEAD

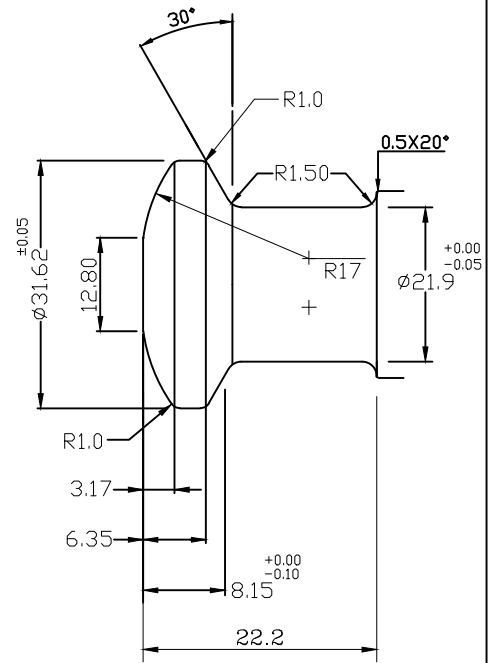

DIE

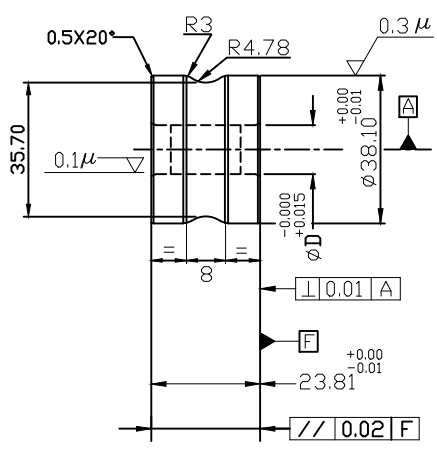

NOTES:-

- (1) CU = CLEARANCE FOR UPPER PUNCH TIP. -0.04 TO -0.055
- (2) CL = CLEARANCE FOR LOWER PUNCH TIP. -0.02 TO -0.035
- (3) D = DIE-BORE.
- (4) CD = CAVITY DEPTH.
- (5) UNLIMITED DIMENSIONS ±0.2
- (6) ALL DIMENSIONS ARE IN MM.
- (7) PUNCHES FROM AISI D1 & DIES FROM D3 STEEL

NAME	DATE	TITLE :- STD. D TOOLING		
DESIGNED	06.04.2015	EURO "D"		
DRAWN	MANISHA			
CHECKED	N.B.S	SCALE	DRG NO.	PROJ:-
APPROVED				

Imperial Pharmachines Pvt. Ltd.

136, SHIVKRIPA INDUSTRIAL ESTATE,
L. B. S. Marg, Vikhroli (West),
Mumbai - 400 083.

Tel : 2578 1989 / 2577 0554
Fax : 91-22-2578 0000
E-Mail : sales1@pharmachine.in
Website : www.pharmachine.in